

ND90L Nudaflat 90

Wall hung consolle 90 cm

• WITHOUT OVERFLOW • ARRANGED FOR 3 HOLES TAP

Complements: **Line taps basin:** ONE - NOKÈ - FOLD - X1
Line accessories: TWO - HOOP - NOKÈ - FOLD

Technical accessories: **Chrome siphon (SIFL/CR) - Telescopic chrome siphon (SIFL066)**
Stop & Go drain (PLSG)
Two piece set chrome tap filters (RF026)
CERAMIC Stop & Go drain (PLCE)
Chrome waste with automatic integrated overflow (PLTPCR)
Waste with automatic integrated overflow and ceramic cover (PLTPCE)
Fixing kit for wall (9002)

Package dim. | Weight **22 kg** | Pz. Pallet n° **10**

UNI EN 14688 - CL00 Dop-No14688

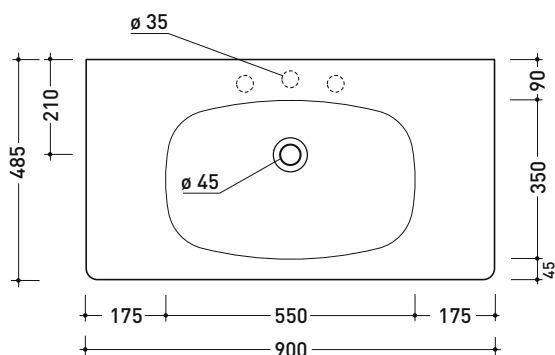

vista zenitale / zenital view

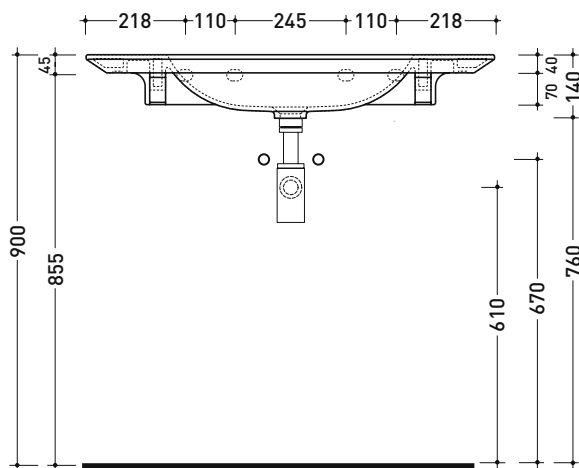

vista frontale / frontal view

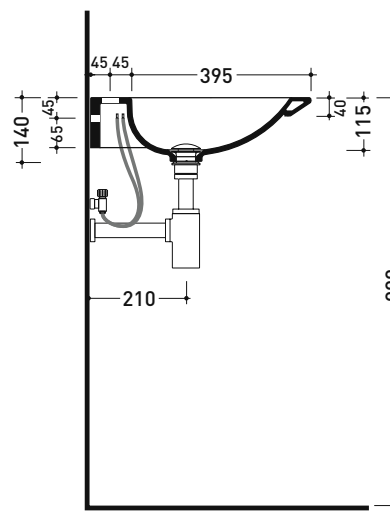

sezione longitudinale / section

sizes in mm

Please consider a 2% tolerance on indicated measurements

CERAMIC: glossy finish



white black

matt finish



milky white carbone argilla cenere nuvola fango rosso rubens petrolio